

Model 7700, 7702, and 7703 Multiplexer Modules

User's Guide

PA-695 Rev. D / October 2006

WARRANTY

Keithley Instruments, Inc. warrants this product to be free from defects in material and workmanship for a period of 1 year from date of shipment.

Keithley Instruments, Inc. warrants the following items for 90 days from the date of shipment: probes, cables, rechargeable batteries, diskettes, and documentation.

During the warranty period, we will, at our option, either repair or replace any product that proves to be defective.

To exercise this warranty, write or call your local Keithley representative, or contact Keithley headquarters in Cleveland, Ohio. You will be given prompt assistance and return instructions. Send the product, transportation prepaid, to the indicated service facility. Repairs will be made and the product returned, transportation prepaid. Repaired or replaced products are warranted for the balance of the original warranty period, or at least 90 days.

LIMITATION OF WARRANTY

This warranty does not apply to defects resulting from product modification without Keithley's express written consent, or misuse of any product or part. This warranty also does not apply to fuses, software, non-rechargeable batteries, damage from battery leakage, or problems arising from normal wear or failure to follow instructions.

THIS WARRANTY IS IN LIEU OF ALL OTHER WARRANTIES, EXPRESSED OR IMPLIED, INCLUDING ANY IMPLIED WARRANTY OF MERCHANTABILITY OR FITNESS FOR A PARTICULAR USE. THE REMEDIES PROVIDED HEREIN ARE BUYER'S SOLE AND EXCLUSIVE REMEDIES.

NEITHER KEITHLEY INSTRUMENTS, INC. NOR ANY OF ITS EMPLOYEES SHALL BE LIABLE FOR ANY DIRECT, INDIRECT, SPECIAL, INCIDENTAL OR CONSEQUENTIAL DAMAGES ARISING OUT OF THE USE OF ITS INSTRUMENTS AND SOFTWARE EVEN IF KEITHLEY INSTRUMENTS, INC., HAS BEEN ADVISED IN ADVANCE OF THE POSSIBILITY OF SUCH DAMAGES. SUCH EXCLUDED DAMAGES SHALL INCLUDE, BUT ARE NOT LIMITED TO: COSTS OF REMOVAL AND INSTALLATION, LOSSES SUSTAINED AS THE RESULT OF INJURY TO ANY PERSON, OR DAMAGE TO PROPERTY.

KEITHLEY

A GREATER MEASURE OF CONFIDENCE

Keithley Instruments, Inc.

Corporate Headquarters • 28775 Aurora Road • Cleveland, Ohio 44139
440-248-0400 • Fax: 440-248-6168 • 1-888-KEITHLEY (534-8453) • www.keithley.com

The following safety precautions should be observed before using this product and any associated instrumentation. Although some instruments and accessories would normally be used with non-hazardous voltages, there are situations where hazardous conditions may be present.

This product is intended for use by qualified personnel who recognize shock hazards and are familiar with the safety precautions required to avoid possible injury. Read and follow all installation, operation, and maintenance information carefully before using the product. Refer to the manual for complete product specifications.

If the product is used in a manner not specified, the protection provided by the product may be impaired.

The types of product users are:

Responsible body is the individual or group responsible for the use and maintenance of equipment, for ensuring that the equipment is operated within its specifications and operating limits, and for ensuring that operators are adequately trained.

Operators use the product for its intended function. They must be trained in electrical safety procedures and proper use of the instrument. They must be protected from electric shock and contact with hazardous live circuits.

Maintenance personnel perform routine procedures on the product to keep it operating properly, for example, setting the line voltage or replacing consumable materials. Maintenance procedures are described in the manual. The procedures explicitly state if the operator may perform them. Otherwise, they should be performed only by service personnel.

Service personnel are trained to work on live circuits, and perform safe installations and repairs of products. Only properly trained service personnel may perform installation and service procedures.

Keithley products are designed for use with electrical signals that are rated Measurement Category I and Measurement Category II, as described in the International Electrotechnical Commission (IEC) Standard IEC 60664. Most measurement, control, and data I/O signals are Measurement Category I and must not be directly connected to mains voltage or to voltage sources with high transient over-voltages. Measurement Category II connections require protection for high transient over-voltages often associated with local AC mains connections. Assume all measurement, control, and data I/O connections are for connection to Category I sources unless otherwise marked or described in the Manual.

Exercise extreme caution when a shock hazard is present. Lethal voltage may be present on cable connector jacks or test fixtures. The American National Standards Institute (ANSI) states that a shock hazard exists when voltage levels greater than 30V RMS, 42.4V peak, or 60VDC are present. A good safety practice is to expect that hazardous voltage is present in any unknown circuit before measuring.

Operators of this product must be protected from electric shock at all times. The responsible body must ensure that operators are prevented access and/or insulated from every connection point. In some cases, connections must be exposed to potential human contact. Product operators in these circumstances must be trained to protect themselves from the risk of electric shock. If the circuit is capable of operating at or above 1000 volts, no conductive part of the circuit may be exposed.

Do not connect switching cards directly to unlimited power circuits. They are intended to be used with impedance limited sources. NEVER connect switching cards directly to AC mains. When connecting sources to switching cards, install protective devices to limit fault current and voltage to the card.

Before operating an instrument, make sure the line cord is connected to a properly grounded power receptacle. Inspect the connecting cables, test leads, and jumpers for possible wear, cracks, or breaks before each use.

When installing equipment where access to the main power cord is restricted, such as rack mounting, a separate main input power disconnect device must be provided, in close proximity to the equipment and within easy reach of the operator.

For maximum safety, do not touch the product, test cables, or any other instruments while power is applied to the circuit under test. ALWAYS remove power from the entire test system and discharge any capacitors before: connecting or disconnecting cables or jumpers, installing or removing switching cards, or making internal changes, such as installing or removing jumpers.

Do not touch any object that could provide a current path to the common side of the circuit under test or power line (earth) ground. Always make measurements with dry hands while standing on a dry, insulated surface capable of withstanding the voltage being measured.

The instrument and accessories must be used in accordance with its specifications and operating instructions or the safety of the equipment may be impaired.

Do not exceed the maximum signal levels of the instruments and accessories, as defined in the specifications and operating information, and as shown on the instrument or test fixture panels, or switching card.

When fuses are used in a product, replace with same type and rating for continued protection against fire hazard.

Chassis connections must only be used as shield connections for measuring circuits, NOT as safety earth ground connections.

If you are using a test fixture, keep the lid closed while power is applied to the device under test. Safe operation requires the use of a lid interlock.

If a  screw is present, connect it to safety earth ground using the wire recommended in the user documentation.

The  symbol on an instrument indicates that the user should refer to the operating instructions located in the manual.

The  symbol on an instrument shows that it can source or measure 1000 volts or more, including the combined effect of normal and common mode voltages. Use standard safety precautions to avoid personal contact with these voltages.

The  symbol indicates a connection terminal to the equipment frame.

The WARNING heading in a manual explains dangers that might result in personal injury or death. Always read the associated information very carefully before performing the indicated procedure.

The CAUTION heading in a manual explains hazards that could damage the instrument. Such damage may invalidate the warranty.

Instrumentation and accessories shall not be connected to humans.

Before performing any maintenance, disconnect the line cord and all test cables.

To maintain protection from electric shock and fire, replacement components in mains circuits, including the power transformer, test leads, and input jacks, must be purchased from Keithley Instruments. Standard fuses, with applicable national safety approvals, may be used if the rating and type are the same. Other components that are not safety related may be purchased from other suppliers as long as they are equivalent to the original component. (Note that selected parts should be purchased only through Keithley Instruments to maintain accuracy and functionality of the product.) If you are unsure about the applicability of a replacement component, call a Keithley Instruments office for information.

To clean an instrument, use a damp cloth or mild, water based cleaner. Clean the exterior of the instrument only. Do not apply cleaner directly to the instrument or allow liquids to enter or spill on the instrument. Products that consist of a circuit board with no case or chassis (e.g., data acquisition board for installation into a computer) should never require cleaning if handled according to instructions. If the board becomes contaminated and operation is affected, the board should be returned to the factory for proper cleaning/servicing.

7700 20-Channel Differential Multiplexer w/Automatic CJC

GENERAL

20 CHANNELS: 20 channels of 2-pole relay input. All channels configurable to 4-pole.

2 CHANNELS: 2 channels of current only input.

RELAY TYPE: Latching electromechanical.

ACTUATION TIME: <3ms.

CAPABILITIES

CHANNELS 1-20: Multiplex one of 20 2-pole or one of 10 4-pole signals into DMM.

CHANNELS 21-22: Multiplex one of 2 2-pole current signals into DMM.

INPUTS

MAXIMUM SIGNAL LEVEL:

Channels (1-20): 300V DC or 300V rms (425V peak) for AC waveforms, 1A switched, 60W, 125VA maximum.

Channels (21-22): 60V DC or 30V rms, 3A switched, 60W, 125VA maximum.

CONTACT LIFE (typ): >10⁵ operations at max signal level.
>10⁶ operations cold switching.

CONTACT RESISTANCE: <1Ω at end of contact life.

CONTACT POTENTIAL: <±500nV typical per contact, 1μV max.

<±500nV typical per contact pair, 1μV max.

OFFSET CURRENT: <100pA.

CONNECTOR TYPE: Screw terminal, #20 AWG wire size.

ISOLATION BETWEEN ANY TWO TERMINALS: >10¹⁰Ω, <100pF

ISOLATION BETWEEN ANY TERMINAL AND EARTH: >10⁹Ω, <200pF

CROSS TALK (50Ω Load):

	w/Internal DMM	w/o Internal DMM*
10MHz:	<-40dB	<-40dB
25MHz:	**	<-25dB

* Channels 24 and 25 are open. Refer to ROUTe:MULTiple command in 27xx User's manual.

** Not valid

INSERTION LOSS (50Ω Source, 50Ω Load):

	w/Internal DMM	w/o Internal DMM*
<0.1dB	1MHz	1MHz
<3db	2MHz	50MHz

* Channels 24 and 25 are open. Refer to ROUTe:MULTiple command in 27xx User's manual.

COMMON MODE VOLTAGE: 300V or 300V rms (425V peak) for AC waveforms between any terminal and chassis.

T/C COLD JUNCTION: 1.0°C (18°-28°C Mainframe Temp)

1.5°C (0°-18°C & 28°-50°C Mainframe Temp).

ENVIRONMENTAL:

OPERATING ENVIRONMENT: Specified for 0°C to 50°C.

Specified to 80% R.H. at 35°C.

STORAGE ENVIRONMENT: -25°C to 65°C.

WEIGHT: 0.45kg (1 lb).

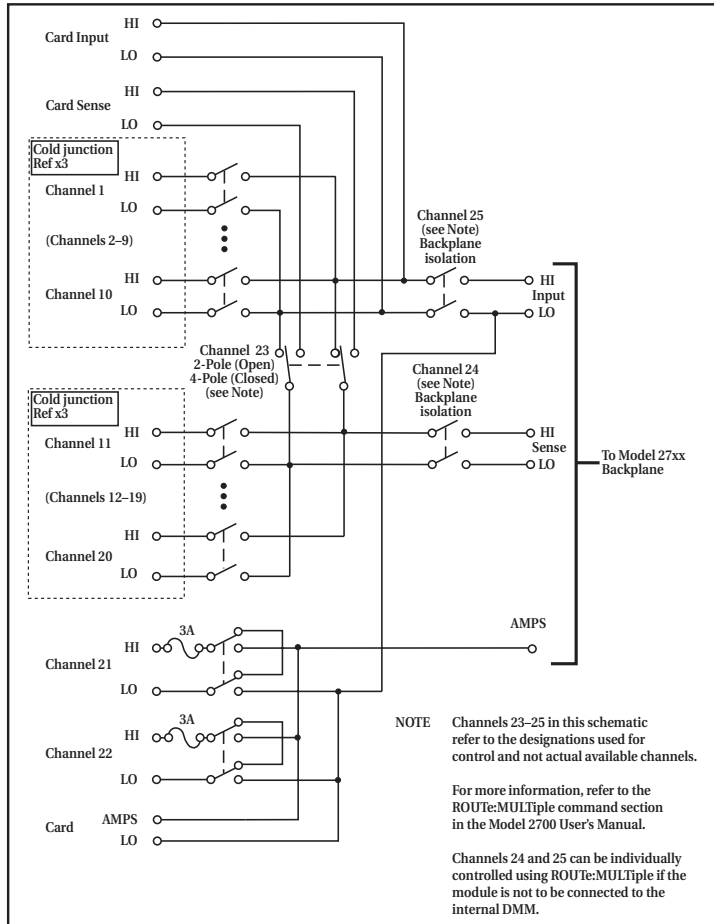

7702 40-Channel Differential Multiplexer

GENERAL

40 CHANNELS: 40 channels of 2-pole relay input.
All channels configurable to 4-pole.

2 CHANNELS: 2 channels of current only input.

RELAY TYPE: Latching electromechanical.

ACTUATION TIME: <3ms.

CAPABILITIES

CHANNELS 1-40: Multiplex one of 40 2-pole or one of 20 4-pole signals into DMM.

CHANNELS 41-42: Multiplex one of 2 2-pole current signals into DMM.

INPUTS

MAXIMUM SIGNAL LEVEL:

Channels (1-40): 300V DC or rms, 1A switched, 60W, 125VA maximum.

Channels (41-42): 60V DC or 30V rms, 3A switched, 60W, 125VA maximum.

CONTACT LIFE (typ): >10⁵ operations at max signal level.
>10⁸ operations cold switching.

CONTACT RESISTANCE: <1Ω at end of contact life.

CONTACT POTENTIAL: <±500nV typical per contact, 1μV max.
<±500nV typical per contact pair, 1μV max.

OFFSET CURRENT: <100pA.

CONNECTOR TYPE: Screw terminal, #20 AWG wire size.

ISOLATION BETWEEN ANY TWO TERMINALS: >10¹⁰Ω, <100pF

ISOLATION BETWEEN ANY TERMINAL AND EARTH: >10⁹Ω, <200pF

CROSS TALK (10MHz, 50Ω Load): <-40dB.

INSERTION LOSS (50Ω Source, 50Ω Load): <0.1dB below 1MHz.
<3dB below 2MHz.

COMMON MODE VOLTAGE: 300V between any terminal and chassis.

ENVIRONMENTAL

OPERATING ENVIRONMENT: Specified for 0°C to 50°C.
Specified to 80% R.H. at 35°C.

STORAGE ENVIRONMENT: -25°C to 65°C.

WEIGHT: 0.5kg (1.1 lb).

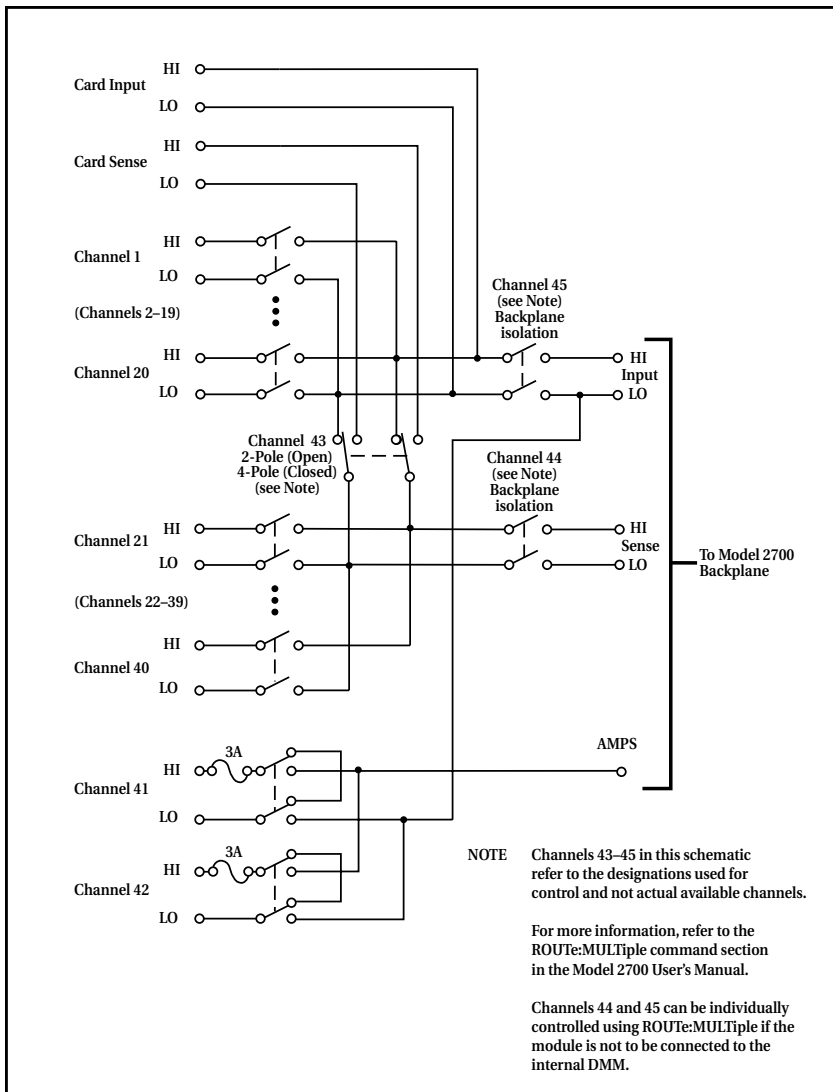

Specifications subject to change without notice.

7703 32-Channel High Speed Differential Multiplexer

GENERAL

32 CHANNELS: 32 channels of 2-pole relay input.
All channels configurable to 4-pole.

RELAY TYPE: Reed.

ACTUATION TIME: <1ms.

CAPABILITIES

CHANNELS 1-32: Multiplex one of 32 2-pole or one of 16 4-pole signals into DMM.

INPUTS

MAXIMUM SIGNAL LEVEL:

Channels (1-32): 300V DC or rms, 0.5A switched, 10W maximum.

Contact Life (typ): >5×10⁴ operations at max signal level.
>10⁸ operations cold switching.

CONTACT RESISTANCE: <1Ω at end of contact life.

CONTACT POTENTIAL: <±3μV typical per contact, 6μV max.
<±3μV typical per contact pair, 6μV max.

OFFSET CURRENT: <100pA.

CONNECTOR TYPE: 50 pin D-sub × 2.

RELAY DRIVE CURRENT: 20mA per channel.

ISOLATION BETWEEN ANY TWO TERMINALS: >10⁹Ω, <200pF.

ISOLATION BETWEEN ANY TERMINAL AND EARTH: >10⁹Ω, <400pF.

CROSS TALK (1 MHz, 50Ω Load): <-40dB.

INSERTION LOSS (50Ω Source, 50Ω Load): <0.35dB below 1MHz.
<3dB below 2MHz.

COMMON MODE VOLTAGE: 300V between any terminal and chassis.

ENVIRONMENTAL

OPERATING ENVIRONMENT: Specified for 0°C to 50°C.
Specified to 40% R.H. at 35°C.

STORAGE ENVIRONMENT: -25°C to 65°C.

WEIGHT: 0.8kg (1.75 lbs).

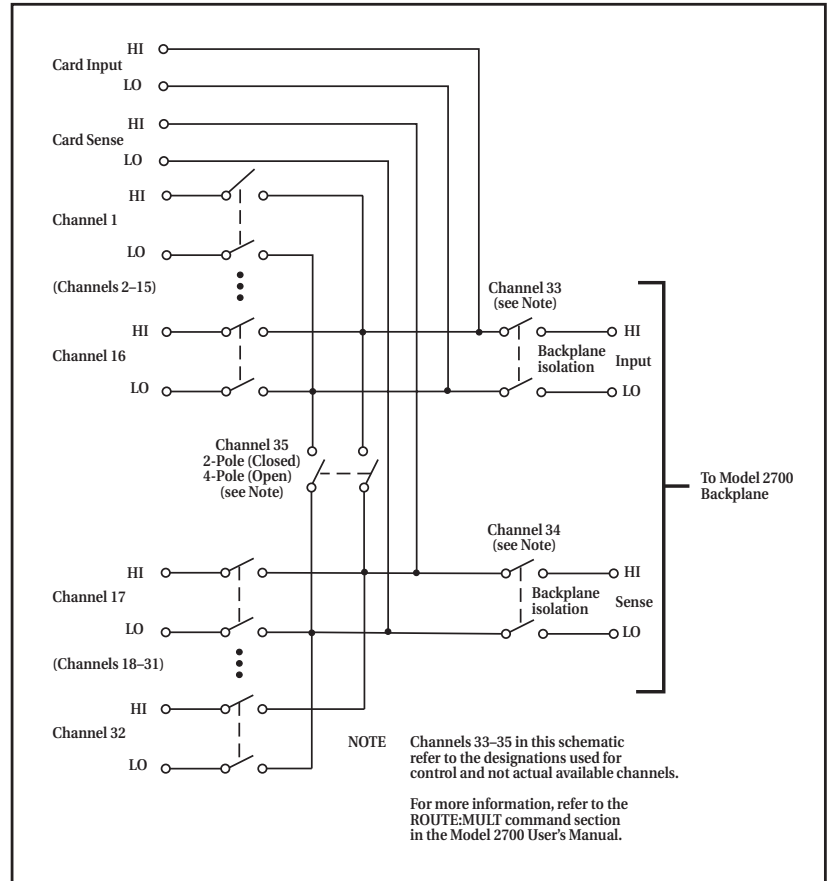

This page intentionally left blank.

Introduction

WARNING Connection and wiring procedures contained in this User's Guide are intended for use by qualified service personnel only. Do not perform these procedures unless qualified to do so. Failure to recognize and observe normal safety precautions could result in personal injury or death.

This document contains information specific to the Models 7700, 7702, and 7703 multiplexer modules. These modules can be used in the following Model 27xx DMM mainframes:

- 7700 Module – This module can be used in Model 2700, 2701, and 2750 mainframes.
- 7702 Module – This module can be used in Model 2700, 2701, 2750, and 2790 mainframes.
- 7703 Module – This module can be used in Model 2700, 2701, and 2750 mainframes.

All references to the Model 27xx apply to the Models 2700, 2701, and 2750.

If you have any questions after reviewing this information, please contact your local Keithley representative or call our Applications Engineers at 1-888-KEITHLEY (1-888-534-8453, U.S. only) or Telefax: 440-498-2990 (Instrument Products).

WARNING Before operating the Model 27xx with an accessory card, verify that the card is properly installed and the mounting screws are tightly fastened. If the mounting screws are not properly connected, an electrical shock hazard may be present.

Operation

Model 7700 Operation of the Model 7700 module is covered in Section 2 of the Models 2700, 2701, and 2750 User's Manuals.

Model 7702 Except for the number of available switching channels and channel number designations, operation of the Model 7702 is the same as operation for the Model 7700. Model 7700 operation is covered in Section 2 of the Models 2700, 2701, and 2750 User's Manuals. Model 7702 operation is also covered in Section 2 of the Model 2790 Reference Manual and Section 3 of the Model 2790 User's Manual. Channel number designations for the Model 7702 is provided in the schematic provided at the beginning of this user's guide.

Model 7703 This module is also similar to the Model 7700. Differences include the number of available channels and the Model 7703 does support amps measurements. Model 7700 operation is covered in Section 2 of the Models 2700, 2701, and 2750 User's Manuals. Channel number designations for the Model 7703 are provided at the end of this User's Guide.

Amps measurements – The 7703 module does not support amps measurements. System channel operation cannot be used to close channels while an amps function (DCI or ICI) is selected. See the Model 27xx Manual for details.

- If an amps function (DCI or ACI) is selected and you attempt to close a system channel, the message “NO AMPS CHAN” will be displayed briefly. For remote programming, error -222 (Parameter data out of range) is generated.
- If a system channel is already closed and you attempt to select the DCI or ACI function, the message “INVALID FUNC” will be displayed briefly. For remote programming, error -221 (Settings conflict) is generated.

Making amps measurements – In order to perform amps measurements, you must use the front panel inputs of the 27xx mainframe. You can still use the 7703 module for other aspects of the test (such as controlling a bias supply for DUT), but you must use multiple channel operation to close channels.

Screw terminal access (Model 7700 and 7702)

Turn the access screw to unlock and open the cover. Press in the access screw to lock.

Figure 1
Screw terminal access

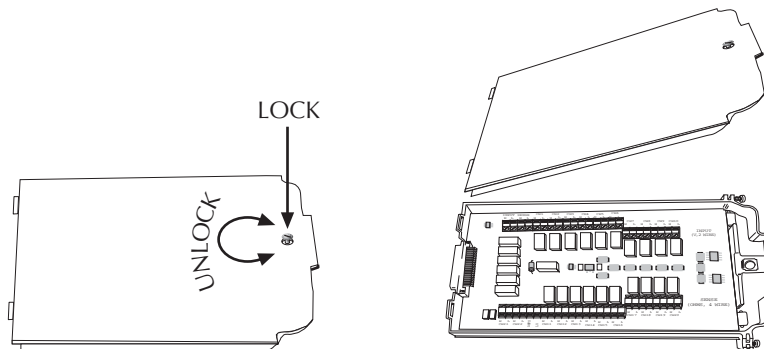

Model 7700 – connections and wiring

The Model 7700 is a 20-channel differential multiplexer module with the following features:

- 2-wire or 4-wire $\frac{3}{4}$ measurement (automatically pairs switches for four wire measurements — $n + 10$)
- Screw terminal connections
- Temperature applications (RTD, thermistor, thermocouple)
- Two protected channels for current measurements (external shunts not required)
- Built-in cold junction reference
- Latching type relays (relays hold their position after power is removed)
- Designed specifically for use with Keithley’s Models 2700, 2701, and 2750 Systems.

Connection information

WARNING The information in this section is intended for qualified service personnel. Do not attempt to perform this procedure unless qualified to do so.

Do not exceed the maximum specifications for the Model 7700.

Connections to DMM functions are provided through the card backplane connector.

- Current provided for through two protected channels (Channels 21 and 22).
- INPUT connections.
- SENSE (3/4 Wire) connections.
- AMP and LO common connections to the DMM are also provided.

Figure 2
Model 7700 screw terminal channel designations

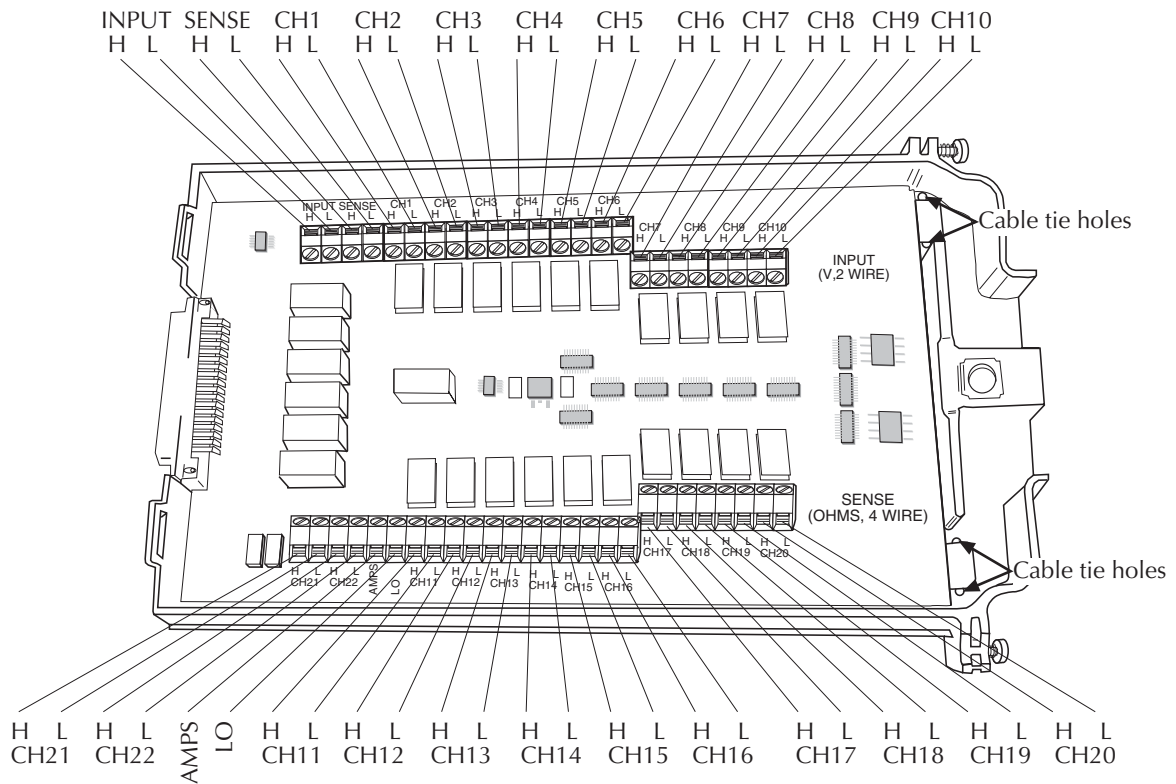

Wiring procedure

WARNING The information in this section is intended for qualified service personnel. Do not attempt to perform this procedure unless qualified to do so.

Use the following procedure to wire the Model 7700 module. Make all connections using correct wire size (up to 20 AWG). Also, make sure to add supplementary insulation around the harness for voltages above 42V peak (see Figure 3).

WARNING All wiring must be rated for the maximum voltage in the system. For example, if 1000V is applied to the front terminals of the Models 2700, 2701, or 2750, the plug-in module wiring must be rated for 1000V.

1. Make sure all power is discharged from the Model 7700 module.
2. Access the screw terminals (see “Screw terminal access” located at the front of this document).
3. Using a small flat-blade screwdriver, loosen terminal screws and install wires as desired. (Figure 3 shows connections to channels 1 and 2).
4. Route wire along wire-path and secure with cable tie as shown.
5. Fill in a copy of the connection log and affix it to the module cover.
6. Close and lock the cover.

Figure 3

Wire dressing — Model 7700

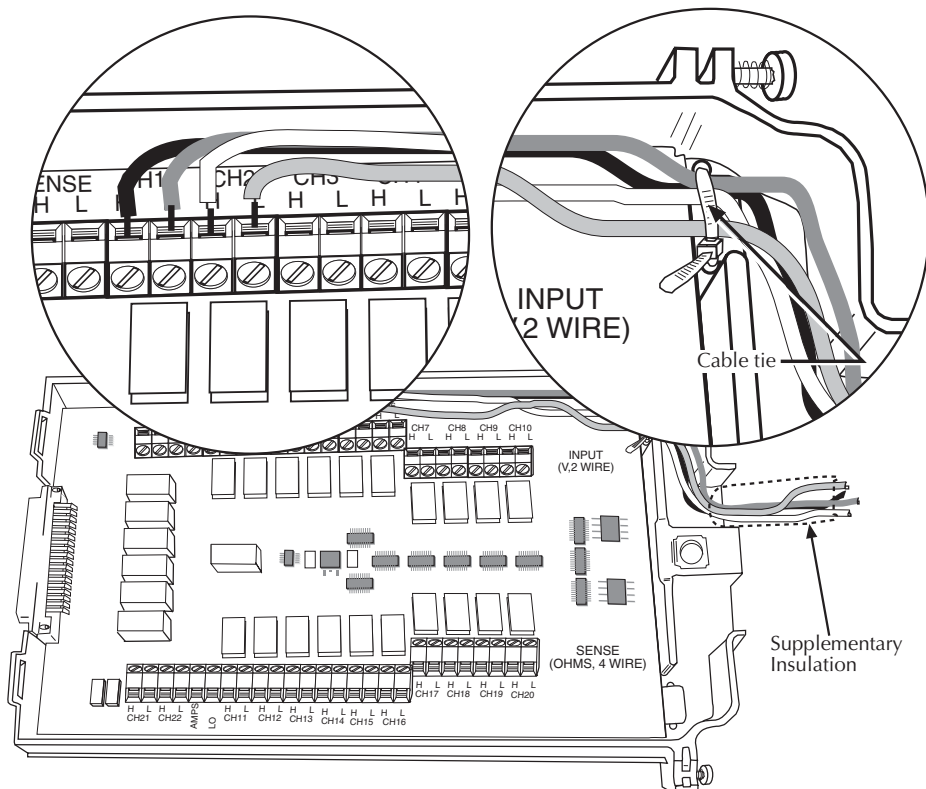

Connection log

Make a copy of Table 1 and affix it to the cover of the Model 7700. Use this to record connection information and channel descriptions as needed.

Table 1
Connection log Model 7700

Channel		Color	Description
AMPS COM	H		
	L		
INPUT	H		
	L		
SENSE	H		
	L		
CH1	H		
	L		
CH2	H		
	L		
CH3	H		
	L		
CH4	H		
	L		
CH5	H		
	L		
CH6	H		
	L		
CH7	H		
	L		
CH8	H		
	L		
CH9	H		
	L		
CH10	H		
	L		
CH11	H		
	L		
CH12	H		
	L		
CH13	H		
	L		
CH14	H		
	L		
CH15	H		
	L		
CH16	H		
	L		
CH17	H		
	L		
CH18	H		
	L		
CH19	H		
	L		
CH20	H		
	L		
AMPS21	H		
	L		
AMPS22	H		
	L		

Model 7702 – connections and wiring

The Model 7702 is a 40-channel differential multiplexer module with the following features:

- 2-wire or 4-wire $\frac{3}{4}$ measurement (automatically pairs switches for four wire measurements — $n + 20$)
- Two protected channels for current measurements (external shunts not required)
- Temperature applications (RTD, thermistor, thermocouple)
- Latching type relays (relays hold their position after power is removed)
- Screw terminal connections
- Designed specifically for use with Keithley’s Models 2700, 2701, 2750 or 2790 Systems.

Connection information

WARNING The information in this section is intended for qualified service personnel. Do not attempt to perform this procedure unless qualified to do so.

Do not exceed the maximum specifications for the Model 7702.

Connections to DMM functions are provided through the card backplane connector.

- Current provided for through two protected channels (Channels 41 and 42).
- INPUT connections.
- SENSE ($\frac{3}{4}$ Wire) connections.
- AMP and LO common connections to the DMM are also provided.

Wiring procedure

WARNING The information in this section is intended for qualified service personnel. Do not attempt to perform this procedure unless qualified to do so.

Use the following procedure to wire the Model 7702 module. Make all connections using correct wire size (up to 20 AWG). Also, make sure to add supplementary insulation around the harness for voltages above 42V peak (see Figure 5).

WARNING All wiring must be rated for the maximum voltage in the system. For example, if 1000V is applied to the front terminals of the Models 2700, 2701, 2750, or 2790, the plug-in module wiring must be rated for 1000V.

1. Make sure all power is discharged from the Model 7702 module.
2. Access the screw terminals (see “Screw terminal access” located at the front of this document).
3. Using a small flat-blade screwdriver, loosen terminal screws and install wires as desired. (Figure 5 shows connections to the Input and Sense).
4. Route wire along wire-path and secure with cable ties as shown.
5. Fill in a copy of the connection log and affix it to the module cover.
6. Close and lock the cover.

Figure 4
Model 7702 Screw terminal channel designs

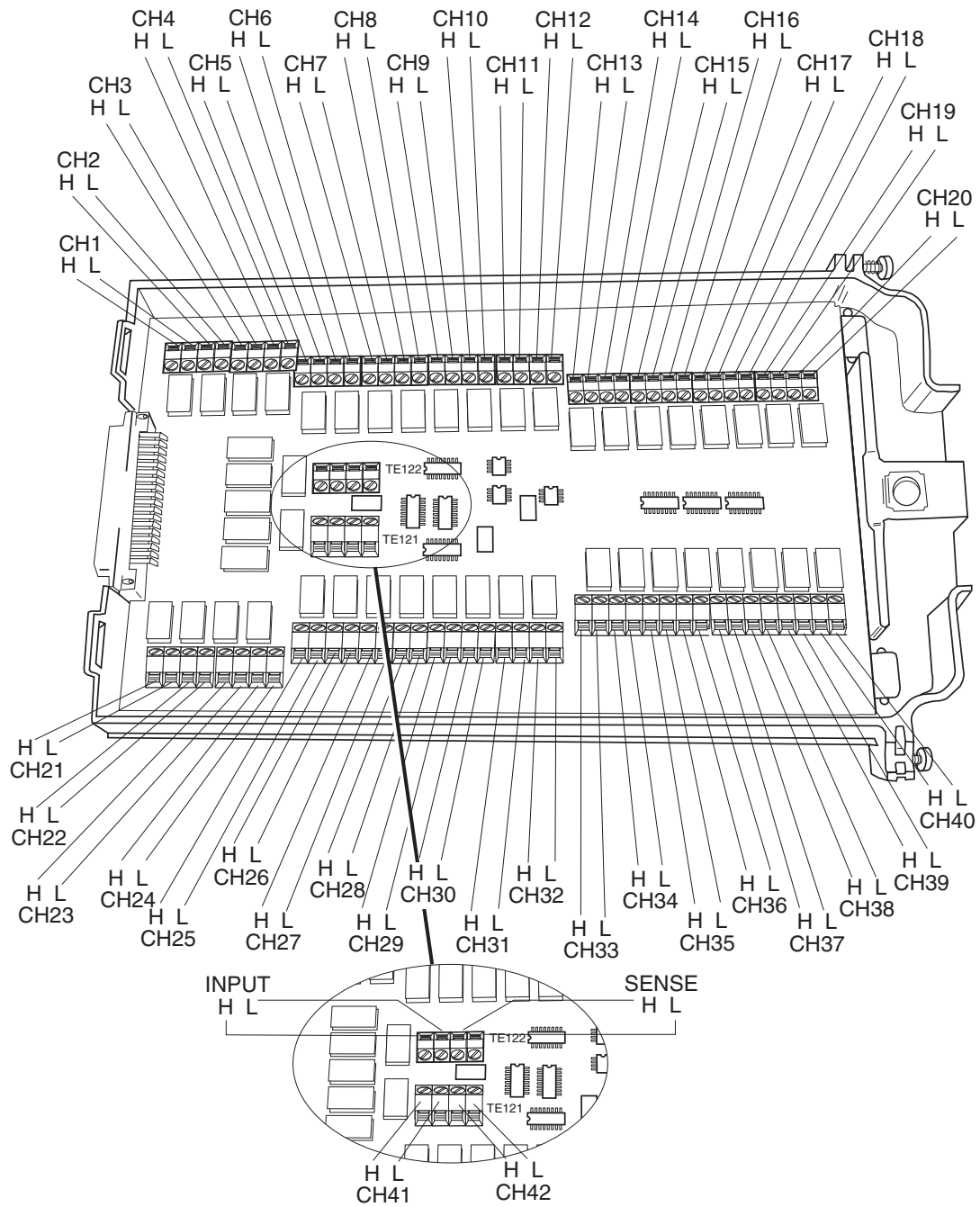
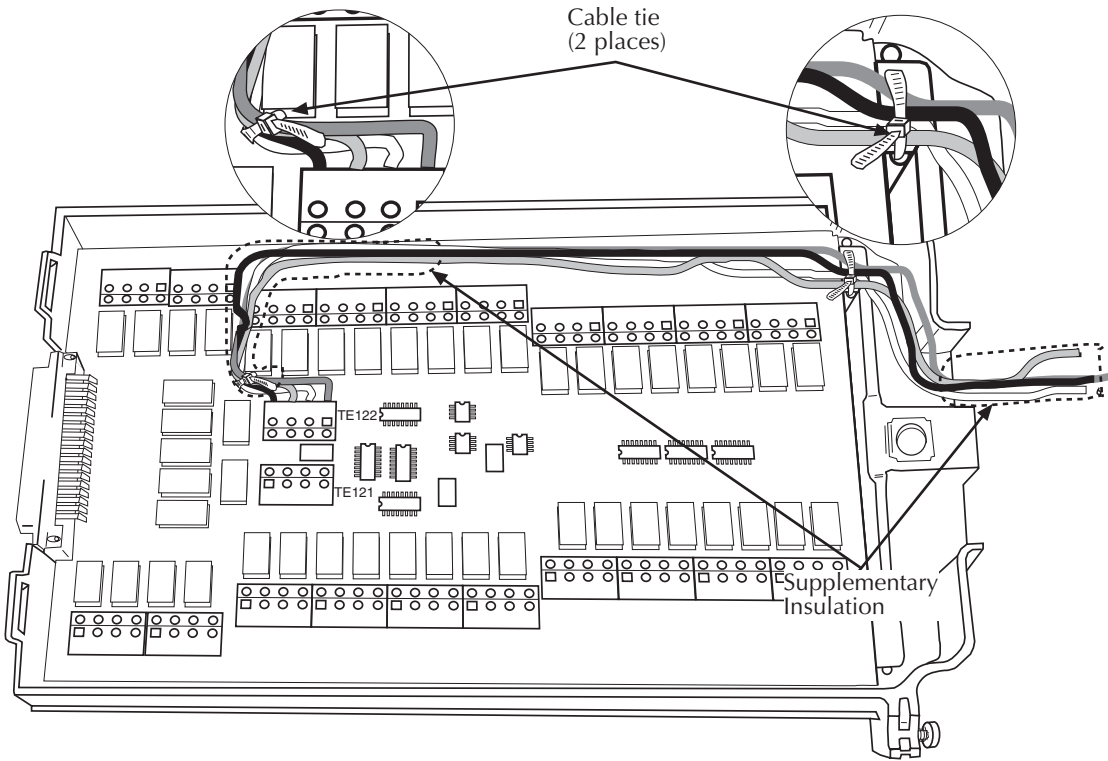

Figure 5
Wire dressing — Model 7702



Connection log

Make a copy of Table 2 and affix it to the cover of the Model 7702. Use this to record connection information and channel descriptions as needed.

Table 2
Connection log Model 7702

Channel	Color	Description	Description	Color	Channel
INPUT	H				
	L				
SENSE	H				
	L				
CH21	H				CH1
	L				
CH22	H				CH2
	L				
CH23	H				CH3
	L				
CH24	H				CH4
	L				
CH25	H				CH5
	L				
CH26	H				CH6
	L				
CH27	H				CH7
	L				
CH28	H				CH8
	L				
CH29	H				CH9
	L				
CH30	H				CH10
	L				
CH31	H				CH11
	L				
CH32	H				CH12
	L				
CH33	H				CH13
	L				
CH34	H				CH14
	L				
CH35	H				CH15
	L				
CH36	H				CH16
	L				
CH37	H				CH17
	L				
CH38	H				CH18
	L				
CH39	H				CH19
	L				
CH40	H				CH20
	L				
AMPS41	H				AMPS42
	L				

Model 7703 – connections and wiring

The Model 7703 is a 32-channel high speed differential multiplexer module with the following features:

- 2-wire or 4-wire $\frac{3}{4}$ measurement (automatically pairs switches for four wire measurements — $n + 16$)
- 50-pin D-Shell connectors ($2 \times$ DB50)
- Temperature applications (RTD or thermistor)
- High-speed non-latching reed relays (relays go to open state after power is removed or *RST)
- Designed specifically for use with Keithley’s Models 2700, 2701, and 2750 Systems.

NOTE The 50-pin D-Shell connector mates with Model 7788.

Card configuration—connections

WARNING The information in this section is intended for qualified service personnel. Do not attempt to perform this procedure unless qualified to do so.

Do not exceed the maximum specifications for the Model 7703 module.

NOTE When looking at the rear connectors of the Model 7703 module, the connector on the left is P1017 and the connector on the right is P1016.

Figure 6
Rear view—Model 7703 Pinouts (P1016 and P1017)

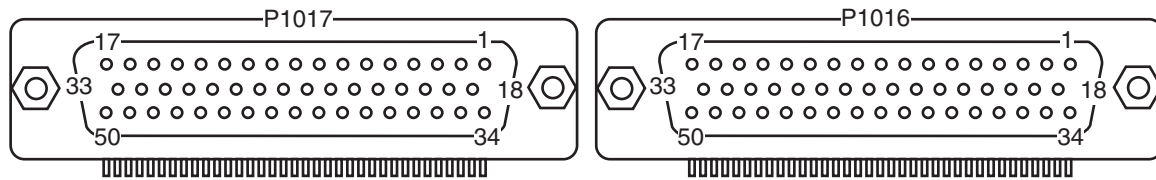

Make all connections using correct wire size (up to 20 AWG). Also, make sure to add supplementary insulation around the harness for voltages above 42V peak (see Figure 7).

WARNING All wiring must be rated for the maximum voltage in the system. For example, if 1000V is applied to the front terminals of the Models 2700, 2701, or 2750, the plug-in module wiring must be rated for 1000V.

Make all connections using correct wire size (up to 20 AWG) (refer to the Model 7788 documentation for specific wiring instructions).

CAUTION If both connectors (P1017 and P1016) are not used, install the extra Model 7788 50-pin D-shell as a plug on the open connector (see Figure 7). If the connector is left open, an electrical shock hazard may be present.

Figure 7
Supplementary insulation and plugging an unused connector

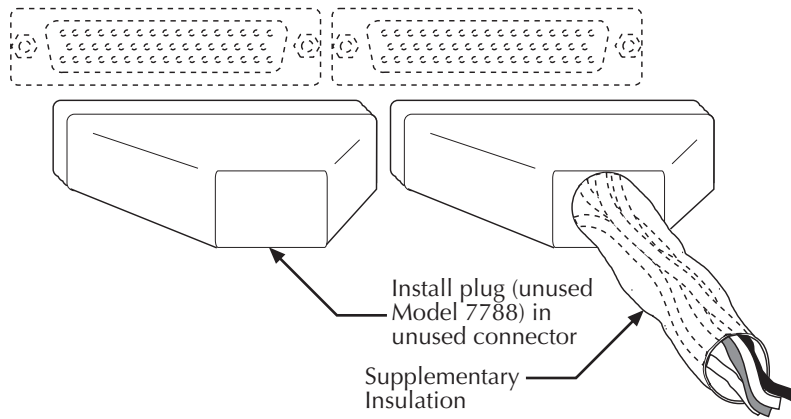

Table 3
Model 7703 channel designations

P1017						P1016					
Pin	CH	Pin	CH	Pin	CH	Pin	CH	Pin	CH	Pin	CH
18	9 HI	30	15 HI	42	29 HI	1	Sense HI	26	5 HI	38	19 HI
19	9 LO	31	15 LO	43	29 LO	2	Sense LO	27	5 LO	39	19 LO
20	10 HI	32	16 HI	44	30 HI	4	Input HI	28	6 HI	40	20 HI
21	10 LO	33	16 LO	45	30 LO	6	Input LO	29	6 LO	41	20 LO
22	11 HI	34	25 HI	46	31 HI	18	1 HI	30	7 HI	42	21 HI
23	11 LO	35	25 LO	47	31 LO	19	1 LO	31	7 LO	43	21 LO
24	12 HI	36	26 HI	48	32 HI	20	2 HI	32	8 HI	44	22 HI
25	12 LO	37	26 LO	49	32 LO	21	2 LO	33	8 LO	45	22 LO
26	13 HI	38	27 HI			22	3 HI	34	17 HI	46	23 HI
27	13 LO	39	27 LO			23	3 LO	35	17 LO	47	23 LO
28	14 HI	40	28 HI			24	4 HI	36	18 HI	48	24 HI
29	14 LO	41	28 LO			25	4 LO	37	18 LO	49	24 LO

Connection log

Make a copy of Table 4 and affix it to the cover of the Model 7703. Use this to record connection information and channel descriptions as needed.

Table 4
Connection log Model 7703

Channel		Color	Description	Description	Color	Channel
INPUT	H					
	L					
SENSE	H					
	L					
CH1	H				H	CH17
	L				L	
CH2	H				H	CH18
	L				L	
CH3	H				H	CH19
	L				L	
CH4	H				H	CH20
	L				L	
CH5	H				H	CH21
	L				L	
CH6	H				H	CH22
	L				L	
CH7	H				H	CH23
	L				L	
CH8	H				H	CH24
	L				L	
CH9	H				H	CH25
	L				L	
CH10	H				H	CH26
	L				L	
CH11	H				H	CH27
	L				L	
CH12	H				H	CH28
	L				L	
CH13	H				H	CH29
	L				L	
CH14	H				H	CH30
	L				L	
CH15	H				H	CH31
	L				L	
CH16	H				H	CH32
	L				L	

Specifications are subject to change without notice.
All Keithley trademarks and trade names are the property of Keithley Instruments, Inc.
All other trademarks and trade names are the property of their respective companies.

KEITHLEY

A G R E A T E R M E A S U R E O F C O N F I D E N C E

Keithley Instruments, Inc.

Corporate Headquarters • 28775 Aurora Road • Cleveland, Ohio 44139 • 440-248-0400 • Fax: 440-248-6168 • 1-888-KEITHLEY (534-8453) • www.keithley.com